

## Single-Axis Linear Stage



### Features

- Non-contact direct-drive linear motor drive for high dynamic response
- Optical linear encoder for high precision
- High stiffness, high precision heavy-duty mechanical guide design
- Excellent positioning accuracy and dynamic performance

### Description

The stage adopts compact and low-profile design, can realize the horizontal high precision, high stiffness linear motion.

### Applications

- Laser cutting
- Semiconductor
- Flat panel display
- Automation

### Interface Definition

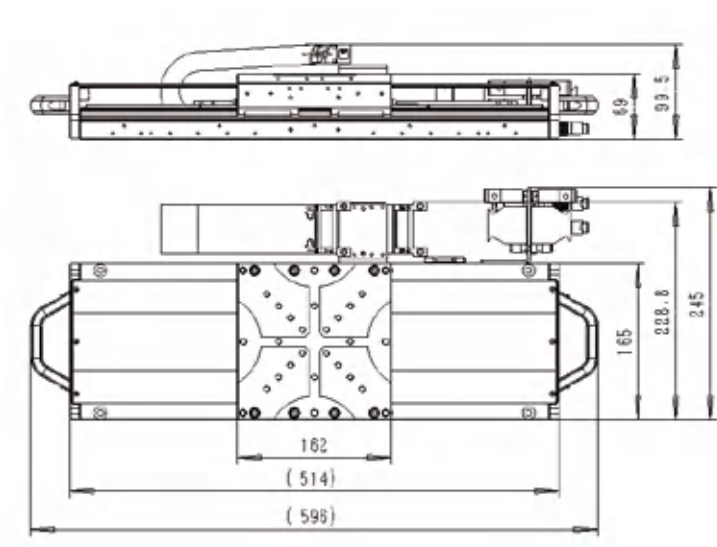

\*Interface dimensions from LTS165

## Technical Specifications

	LTS165-100	LTS165-200	LTS165-300	LTS165-400	LTS165-500	LTS165-600
Travel range	100 mm	200 mm	300 mm	400 mm	500 mm	600 mm
Max. velocity	2 m/s					
Max. acceleration	3 g					
Accuracy	±1 μm	±1.5 μm	±1.5 μm	±1.5 μm	±2 μm	±2 μm
Bidirectional repeatability	±0.5 μm					
Straightness	±2.5 μm	±4 μm	±6 μm	±8 μm	±9 μm	±10 μm
Pitch	29 μrad (6 arcsec)	40 μrad (8.2 arcsec)	58 μrad (12 arcsec)	70 μrad (14.4 arcsec)	80 μrad (16.5arcsec)	90 μrad (18.6arcsec)
Roll	29 μrad (6 arcsec)	40 μrad (8.2 arcsec)	58 μrad (12 arcsec)	70 μrad (14.4 arcsec)	80 μrad (16.5arcsec)	90 μrad (18.6arcsec)
Yaw	29 μrad (6 arcsec)	40 μrad (8.2 arcsec)	58 μrad (12 arcsec)	70 μrad (14.4 arcsec)	80 μrad (16.5arcsec)	90 μrad (18.6arcsec)
<b>Mechanical properties</b>						
Moving mass (without payload)	2.9 Kg					
Max. load	40 Kg					
Stage mass	9.1 Kg	10.8 Kg	12.5 Kg	14.2 Kg	15.8 Kg	17.5 Kg
Dimensions	396 mmX245 mm X99.5 mm	496 mmX245 mm X99.5 mm	596 mmX245 mm X99.5 mm	696 mmX245 mm X99.5 mm	796 mmX245 mm X99.5 mm	896 mmX245 mm X99.5 mm
Material	Aviation aluminum,black anodized					

## Customization Information

The series is configured with options that can be selected based on the user's actual application. Options include travel, encoder, and more.

Table 1 Travel Options

-100	105mm travel stroke platform with linear motors and limit
-200	205mm travel stroke platform with linear motors and limit
-300	305mm travel stroke platform with linear motors and limit
-400	405mm travel stroke platform with linear motors and limit
-500	505mm travel stroke platform with linear motors and limit
-600	605mm travel stroke platform with linear motors and limit

Table 2 Encoder Options

-S1	Incremental analog optical linear encoder, 1Vpp
-S2	Incremental digital optical linear encoder, RS422
-S3	Absolute optical linear encoder, BISS