

## Gimbals & Optical Mounts



### Features

- 360° infinity rotation in 2 axes with gimbal system
- Non-contact torque motor drive for high dynamic response
- High stiffness, high precision cross roller guide
- Built-in slip ring with long-lifetime

### Description

The stage adopts large-size aperture and orthogonality design. High-precision, high-stiffness 360-degree infinity rotation for pitching and vertical rotation.

### Applications

- Laser guidance
- LiDAR and air target tracking
- Photoelectric sensors and forward-looking infrared testing
- Angle testing of gyroscopes
- Acceleration testing of inertial units

### Interface Definition

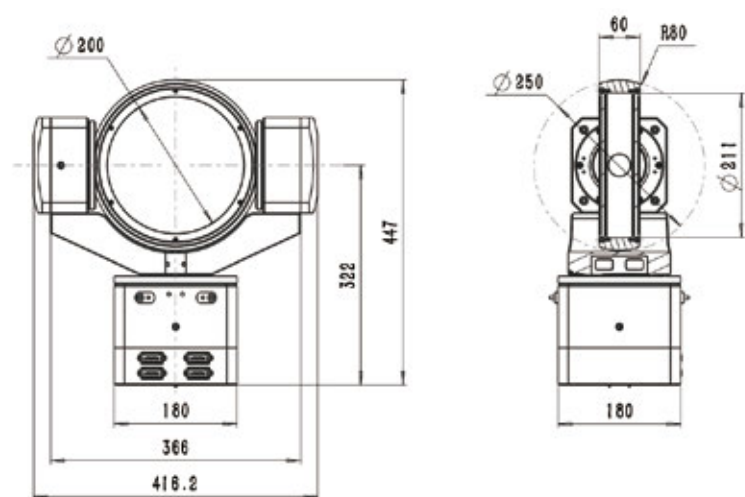

\*Interface dimensions from GS200

## Technical Specifications

	GS100-00	GS150-00	GS200-00
Travel range	360° continuous rotation/pitch		
Max. velocity	100 rpm		
Max. acceleration	100 rpm		
Accuracy	±24 μrad to ±192 μrad (±5 arcsec to ±40 arcsec)		
AZ repeatability	19.4 μrad (4 arcsec)		
EL repeatability	14.5 μrad (3 arcsec)		19.4 μrad (4 arcsec)
Axis wobble	97 μrad (20 arcsec)		
Orthogonality	72 μrad (15 arcsec)		
<b>Mechanical properties</b>			
Max. load	6.8 Kg		16 Kg
Inertia AZ	0.046 Kg·m <sup>2</sup>	0.088 Kg·m <sup>2</sup>	0.277 Kg·m <sup>2</sup>
Inertia EL	0.001 Kg·m <sup>2</sup>	0.004 Kg·m <sup>2</sup>	0.016 Kg·m <sup>2</sup>
Stage mass(without mirror)	9.5 Kg	11.1 Kg	22 Kg
Height to mirror centerline	181 mm	220 mm	322 mm
Hollow aperture	95 mm	144.3 mm	206 mm
Material	Aviation aluminum, black anodized		

## Customization Information

The series is configured with options that can be selected based on the user's actual application. Options include hollow aperture, encoder, and more.

Table 1 Aperture Option

-100	100mm hollow size with linear motor and limit
-150	150mm hollow size with linear motor and limit
-200	200mm hollow size with linear motor and limit

Table 2 Encoder Options

-S1	Incremental analog optical linear encoder, 1Vpp
-S2	Incremental digital optical linear encoder, RS422
-S3	Absolute optical linear encoder, BISS