

Air-Bearing Rotary Stage



Features

- High-load and precision air-bearing design
- High repeatability and positioning accuracy
- High level of machining technology
- Customized requirements accepted

Description

The stage provides ultra-smooth motion, arc-second accuracy and repeatability; the lightweight design makes the product lighter for easier integration.

Applications

- Semiconductor equipment and laser field

Interface Definition

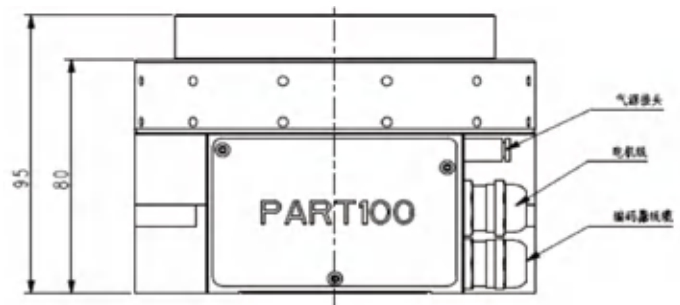
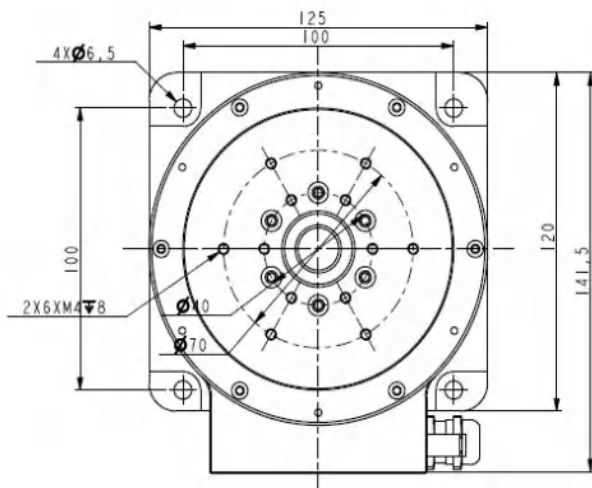

*Interface dimensions from PART100

Technical Specifications

PART100	
Tabletop diameter	100 mm
Height	95 mm
Hollow aperture	25 mm
Max. velocity	600 rpm@48V
Peak torque	3.9 N.m
Continuous torque	3.2 N.m
Accuracy	±1.5 arcsec
Bidirectional repeatability	±1 arcsec
Max. load_Axial	53 Kg
Max. load_Radial	17 Kg
Axial error motion (Synchronous)	<100 nm
Radial error motion(Synchronous)	<200 nm
Tilt error motion (Synchronous)	<2.5 urad (0.5 arcsec)
Operating pressure	0.5 Mpa
Air consumption	<25 L/min
Total mass	4 kg

*Rotation velocity 60rpm based on the standard GBT+17421.7-2016(ISO230-7-2006)and GB/T17421.22000 as well as the temperature (22°±0.5°C).